

MONUMENT COVER

NOTES:

1. MACHINE BEARING FACES OF COVER AND CASE TO INSURE POSITIVE FIT.
2. MATERIAL SHALL CONFORM TO THE "1994 STANDARD SPECIFICATIONS FOR ROAD, BRIDGE AND MUNICIPAL CONSTRUCTION" PREPARED BY THE WASHINGTON STATE DEPT. OF TRANSPORTATION AND AMERICAN PUBLIC WORKS ASSOCIATION, WASHINGTON STATE CHAPTER.

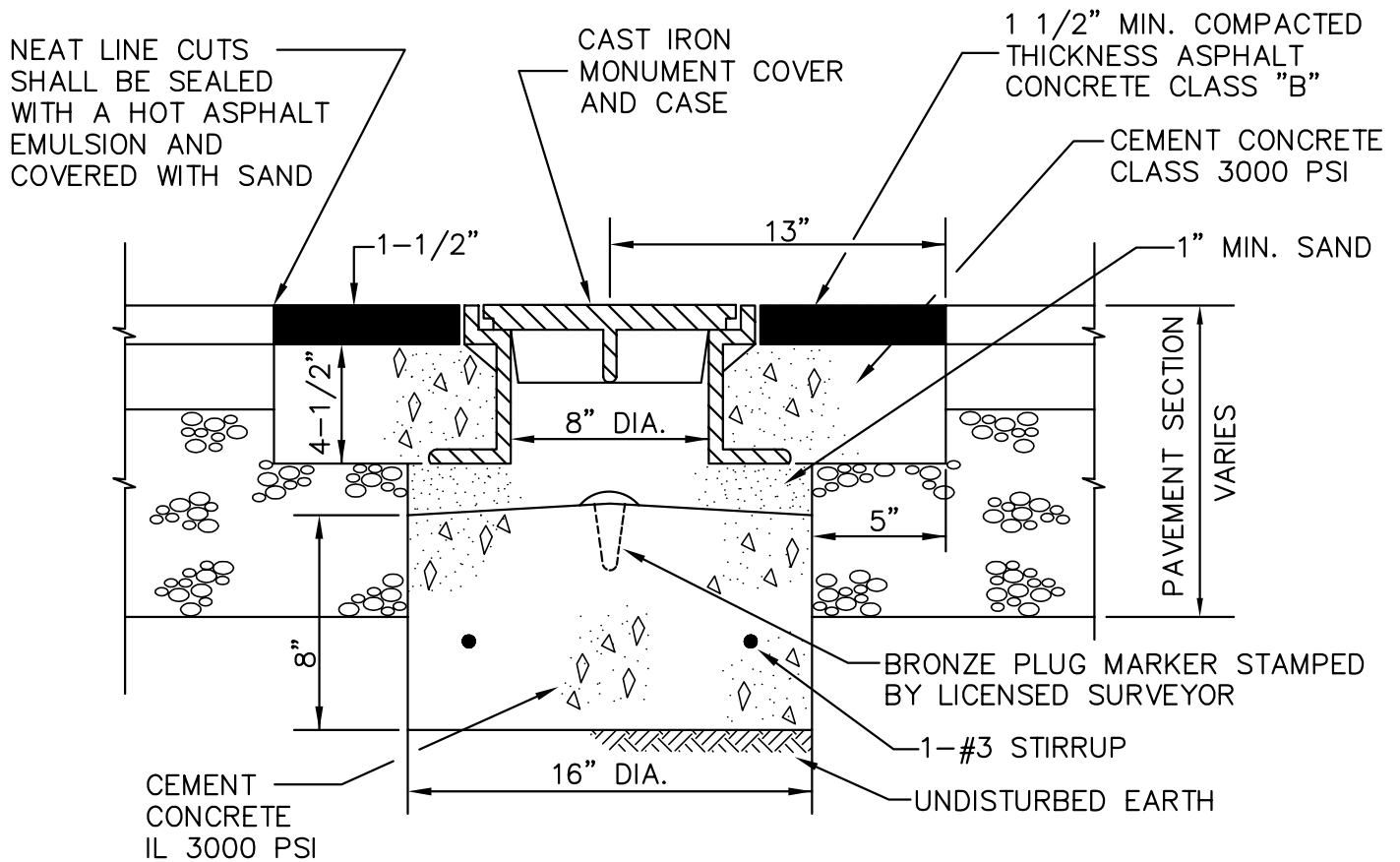

POURED MONUMENT IN PLACE

CITY OF CASTLE ROCK			
POURED MONUMENT IN PLACE			
APPROVED:			DWG. NO.
_____			CRO09ST
BY CITY		DATE	
DATE:	DRWN:	CHKD:	SCALE:
2/06	M.C.	T.J.O.	NONE