

SECTION A-A

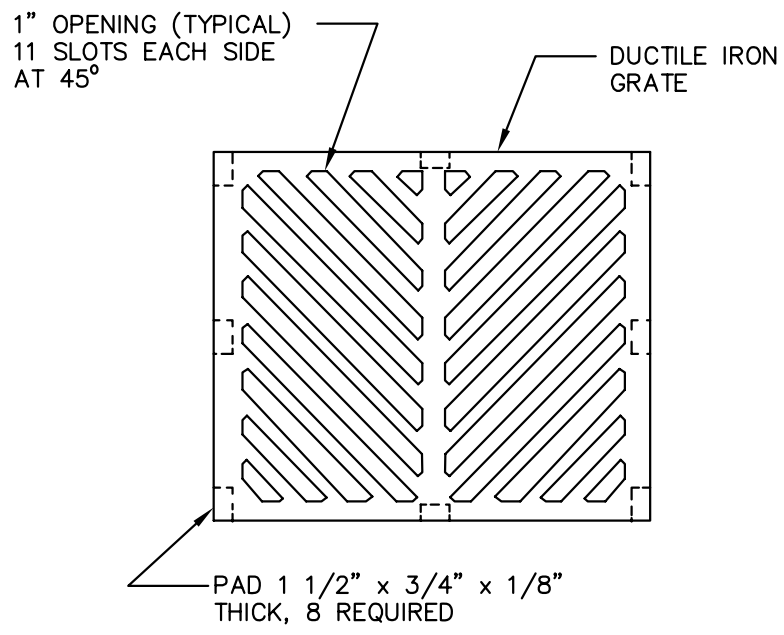

NOTES:

1. MATERIAL SHALL CONFORM TO THE "1994 STANDARD SPECIFICATIONS FOR ROAD, BRIDGE AND MUNICIPAL CONSTRUCTION" PREPARED BY THE WASHINGTON STATE DEPARTMENT OF TRANSPORTATION AND AMERICAN PUBLIC WORKS ASSOCIATION, WASHINGTON STATE CHAPTER.
2. WHEN ROAD PROFILE, EXCEEDS 6% "VANED" GRATES SHALL BE INSTALLED IN LIEU OF THE "HERRING BONE" GRATE, AT THE DISCRETION OF THE CITY.

CITY OF CASTLE ROCK			
CATCH BASIN FRAME AND GRATE			
APPROVED:			DWG. NO.
_____			CR006SW
BY CITY		DATE	
DATE:	DRWN:	CHKD:	SCALE:
2/06	J.H.	T.J.O.	NONE